

AUTOOL[®]

AUTOOL LM707

Refrigerant Recovery Machine

User Manual

用户手册

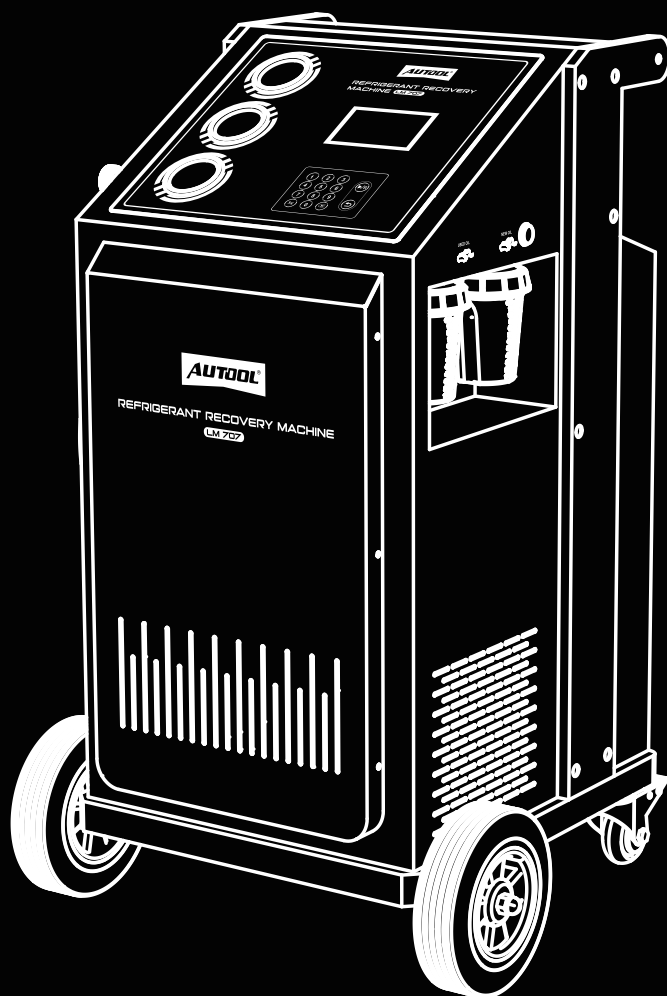



深圳市偶然科技有限公司
AUTOTOOL TECHNOLOGY CO.,LTD

- 🌐 www.autooltech.com
- ✉ aftersale@autooltech.com
- ☎ +86-755-2330 4822 / +86-400 032 0988
- 📍 Hangcheng Jinchi Industrial Park, Bao'an, Shenzhen, China / 广东省深圳市宝安区航城锦驰产业园
- 🏢 企业标准/Corporate Standard: Q/OR 005-2023



COPYRIGHT INFORMATION

Copyright

- All rights reserved by AUTOOL TECH. CO., LTD. No part of this publication may be reproduced, stored in a retrieval system, or transmitted in any form or by any means, electronic, mechanical, photocopying, recording or otherwise, without the prior written permission of AUTOOL. The information contained herein is designed only for the use of this unit. AUTOOL is not responsible for any use of this information as applied to other units.
 - Neither AUTOOL nor its affiliates shall be liable to the purchaser of this unit or third parties for damages, losses, costs, or expenses incurred by the purchaser or third parties as a result of: accident, misuse, or abuse of this unit, or unauthorized modifications, repairs, or alterations to this unit, or failure to strictly comply with AUTOOL operating and maintenance instructions.
 - AUTOOL shall not be liable for any damages or problems arising from the use of any options or any consumable products other than those designated as original AUTOOL products or AUTOOL approved products by AUTOOL.
 - Other product names used herein are for identification purposes only and may be trademarks of their respective owners. AUTOOL disclaims any and all rights in those marks.
-

Trademark

Manual are either trademarks, registered trademarks, service marks, domain names, logos, company names or are otherwise the property of AUTOOL or its affiliates. In countries where any of the AUTOOL trademarks, service marks, domain names, logos and company names are not registered, AUTOOL claims other rights associated with unregistered trademarks, service marks, domain names, logos, and company names. Other products or company names referred to in this manual may be trademarks of their respective owners. You may not use any trademark, service mark, domain name, logo, or company name of AUTOOL or any third party without permission from the owner of the applicable trademark, service mark, domain name, logo, or company name. You may contact AUTOOL by visiting AUTOOL at <https://www.autooltech.com>, or writing to aftersale@autooltech.com, to request written permission to use materials on this manual for purposes or for all other questions relating to this manual.

TABLE OF CONTENTS

| | |
|--|----|
| Cautions | 2 |
| Precautions | 2 |
| Product Introduction | 3 |
| Overview | 3 |
| Equipment functions | 3 |
| Technical specifications | 3 |
| Product Structure | 4 |
| Structure diagram | 4 |
| Control panel description: | 5 |
| Internal structure | 5 |
| Operating Instructions | 6 |
| Connecting the equipment to the vehicle | 6 |
| High and low pressure valve operation guidelines | 6 |
| Tank fill | 7 |
| Recovery | 9 |
| Vacuum | 10 |
| Charge | 12 |
| Auto. mode | 13 |
| Equipment maintenance | 14 |
| Electronic scale calibration | 19 |
| Maintenance Service | 22 |
| Maintenance | 22 |
| Warranty | 23 |
| Warranty access | 23 |
| Disclaimer | 23 |
| Return & Exchange Service | 24 |
| Return & Exchange | 24 |

CAUTIONS

Precautions



Before using this equipment, please carefully read this manual to ensure proper operation and to avoid causing personal injury or damage to the equipment.

- ▶ Users of this equipment must be familiar with the repair and maintenance operations of automotive air conditioning to avoid operational errors that could result in damage to the equipment or the air conditioning system.
- ▶ During operation, wear protective gloves and goggles to prevent refrigerant gas or liquid from coming into contact with the skin and eyes.
- ▶ Do not use this equipment near open flames or high-temperature objects.
- ▶ Do not expose the equipment to direct sunlight or rain.
- ▶ Avoid contact between the equipment and corrosive liquids and gases.
- ▶ This equipment is only for use with R134a Refrigerant. Mixing other types of refrigerants is strictly prohibited.
- ▶ Before operating, check the type of refrigerant used in the automotive air conditioning system and turn off the car engine.
- ▶ The actual usage capacity of the internal tank should be 80% of its maximum capacity (the internal tank capacity is 12kg) to avoid severe accidents caused by additional pressure from external factors.
- ▶ To ensure optimal recharging functions, the internal tank should not contain less than 3kg of refrigerant; otherwise, recharging may not be possible.
- ▶ When discharging the refrigerant oil from the car compressor, bubbles generally form. Users must be familiar with the repair and maintenance operations of automotive air conditioning to avoid operational errors that could result in damage to the equipment or the air conditioning system. The amount of oil to be added is determined by the amount discharged, and overfilling should be avoided.
- ▶ Regularly check the oil level and quality of the vacuum pump. The vacuum pump must not operate without oil.
- ▶ The recovery procedure should be started no more than 10 times per hour; otherwise, the compressor may be damaged.
- ▶ During daily maintenance, ensure that the vacuum pump oil inside the equipment is added to the normal level (this can be observed by opening the main door of the equipment).
- ▶ The equipment contains precision control components; do not attempt unauthorized disassembly or repair. If needed, conduct repairs under the guidance of a professional.

PRODUCT INTRODUCTION

Overview

- This equipment is a refrigerant recovery machine designed for the R134a refrigerant in malfunctioning vehicle air conditioning systems. It performs various operations such as refrigerant recovery, electronic scale recharging, vacuuming, and refrigerant oil recharging, all of which can be fully automated.
-

Equipment functions

- **External Tank Recharging Function:** Replenishes the internal tank inside the equipment with refrigerant.
 - **Recovery Function:** Recovers refrigerant from the R134a air conditioning system and stores it in the equipment's internal tank, purifying and regenerating the refrigerant during the recovery process.
 - **Vacuumping Function:** Vacuuming the refrigeration system.
 - **Recharging Function:** Precisely refills the vehicle's air conditioning system with refrigerant stored in the equipment's internal tank.
 - **Automatic Operation Function:** Allows the equipment to automatically complete the processes of recovery, vacuuming, and recharging.
 - **Equipment Maintenance Function:** Maintains equipment components, including "internal tank cleaning", "filter data reset", "vacuum pump oil data reset", and "electronic scale calibration".
 - To ensure thorough recovery and precise recharging, the equipment includes a pipeline compensation feature. Before each tank inversion and recovery operation, the pipeline is automatically evacuated. After each recharging operation, the refrigerant remaining in the pipeline is automatically recovered into the equipment's internal tank.
-

Technical specifications

| | |
|-------------------------------|-----------------------|
| Power supply | AC 220V / 50HZ |
| Power rating | 800W |
| Operating ambient temperature | 10°C~50°C |
| Electronic scale accuracy | ±10g |
| Recovery capacity | 400g/min |
| Vacuum pump capacity | 5Pa |
| Internal tank capacity | 12Kg |
| Recharging rate | 800g/min |

PRODUCT STRUCTURE



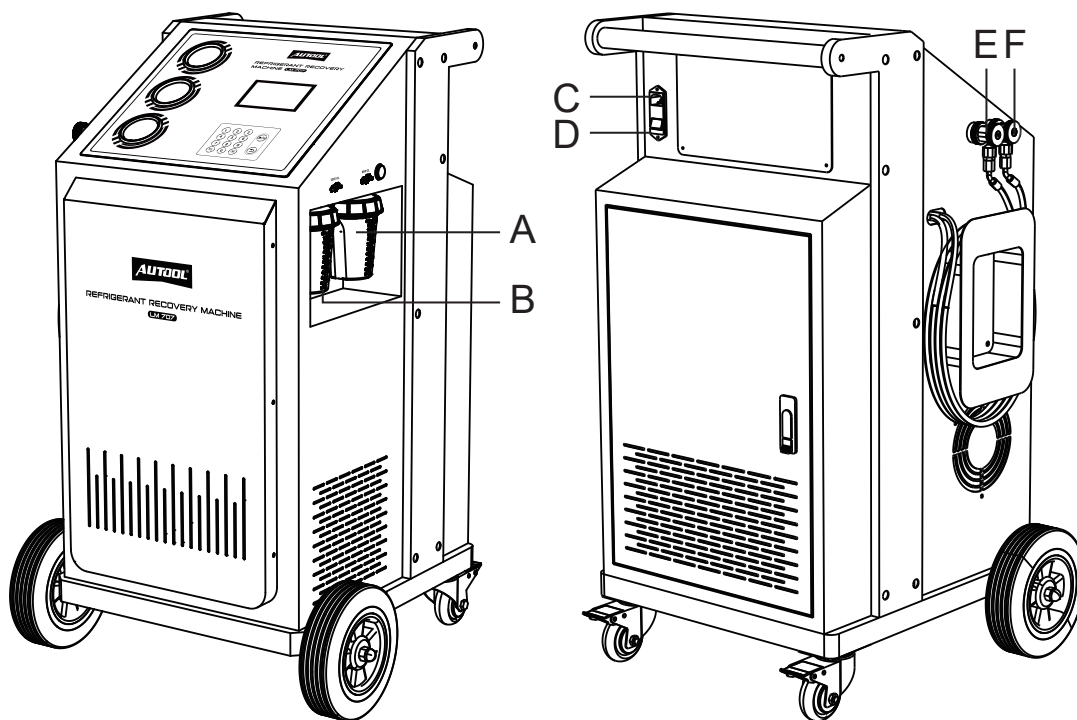

Structure diagram

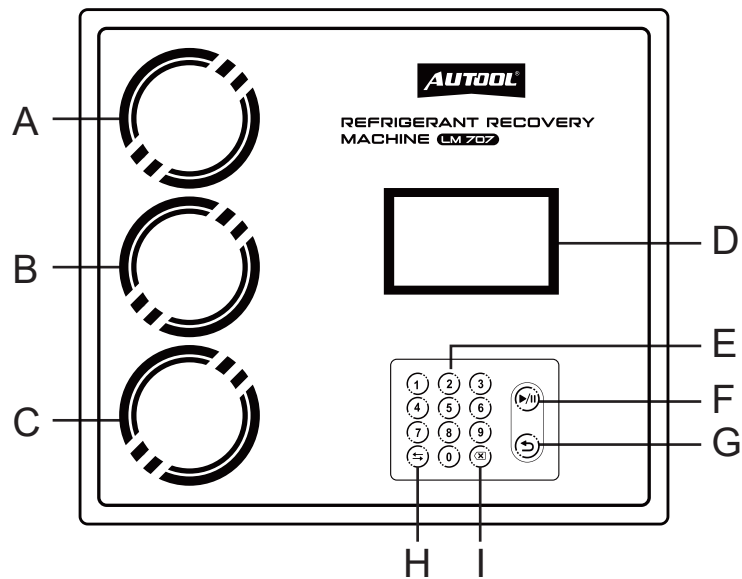

| | | | |
|----------|------------------------|----------|-------------------------|
| A | New Oil Bottle | B | Used-Oil Bottle |
| C | Power Socket | D | Power Switch |
| E | Low-pressure Connector | F | High-pressure Connector |

Control panel description



| | | | |
|----------|--|----------|---|
| A | High-pressure Gauge | B | Low-pressure Gauge |
| C | Tank Pressure Gauge | D | Display Screen |
| E |  Numeric Buttons (0~9) | F |  Start / Pause Button |
| G |  Exit Button | H |  Function Selection Button |
| I |  Undo Button | | |

Internal structure

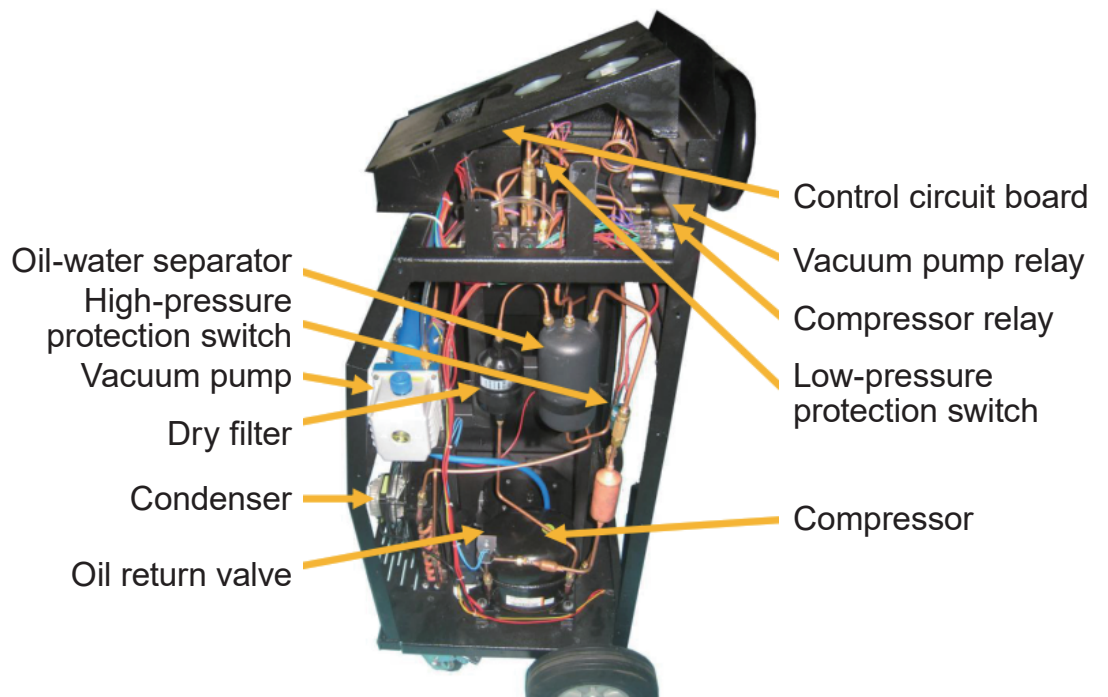

OPERATING INSTRUCTIONS

Connecting the equipment to the vehicle

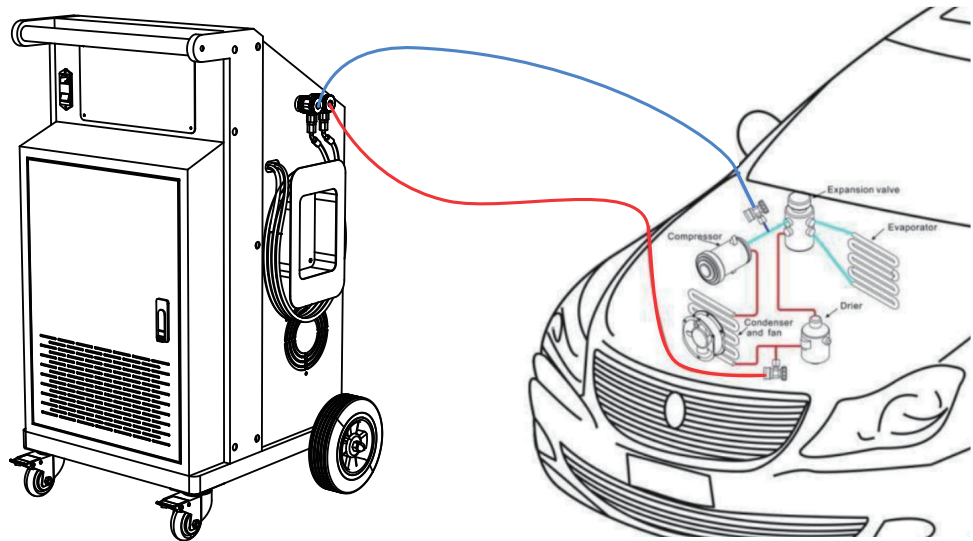

High and low pressure valve operation guidelines

During equipment operation, the system will prompt multiple times to "close" or "open" the high and low-pressure valves. The operations are defined as follows:

Close the High and Low Pressure Valves

- As shown in the diagram below, closing the high and low-pressure valves refers to turning the valves counterclockwise (the arrow on the valves is labeled "open"), opposite to the direction indicated by the arrow on the valves.

Diagram illustrating closing the A/C quick connector

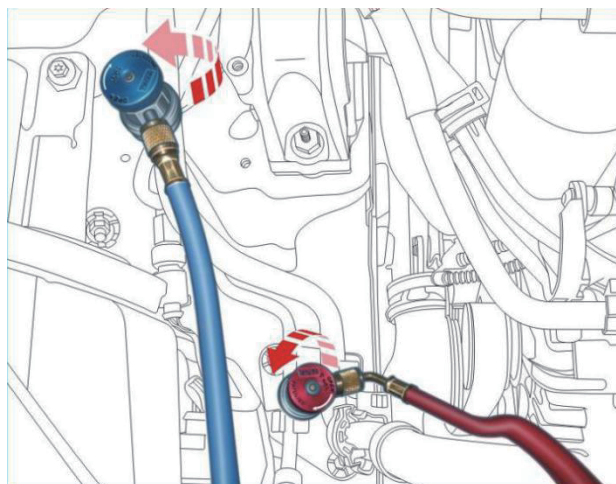

Counter-clockwise tightening of the A/C quick connector

Open the High and Low Pressure Valves

- As shown in the diagram below, opening the high and low-pressure valves involves turning the valves clockwise, following the direction indicated by the arrow on the valves.

Diagram illustrating opening the A/C quick connector

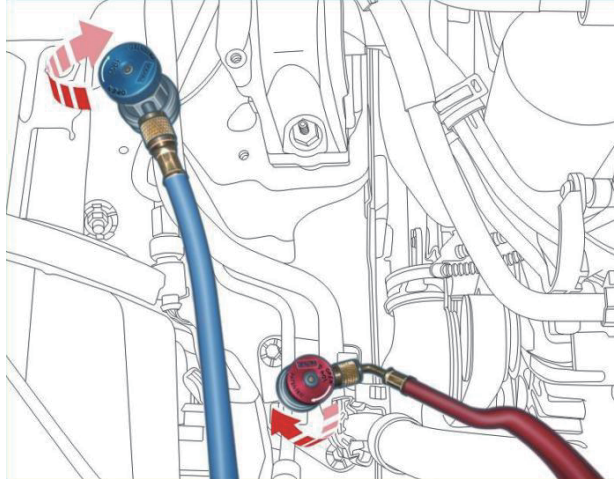

Clockwise tightening of the A/C quick connector

Tank fill

When the equipment leaves the factory, the internal tank does not contain any refrigerant so it is necessary to refill the refrigerant into the equipment's internal tank before use. The recommended recharging amount is between 3-6kg (it is not recommended to use the equipment when the internal tank contains less than 3kg of refrigerant, and the optimal usage range is between 3-6kg). The procedure is as follows:

- Attach the blue hose to the low-pressure connector on the equipment.
- Connect the quick connector of the blue hose to the connector on the external tank.
- Close the quick connector of the red hose.

Operation Flowchart

- On the main menu interface, use the selection key to choose the desired function, then press the enter menu key to enter the selected function.



Select the "TANK FILL" function to enter the menu.

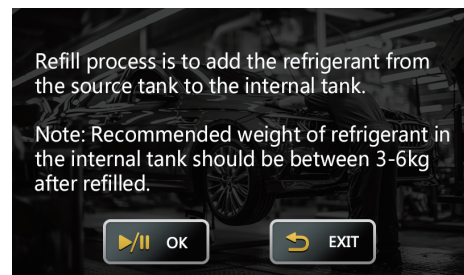

Confirm or exit based on the content.

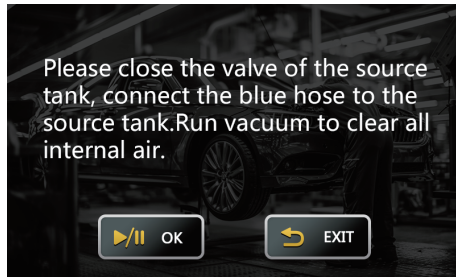

Confirm or exit based on the content.

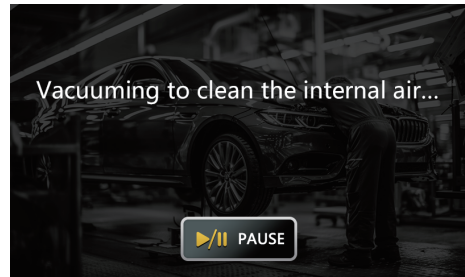

Vacuumping is operating normally; this interface appears.

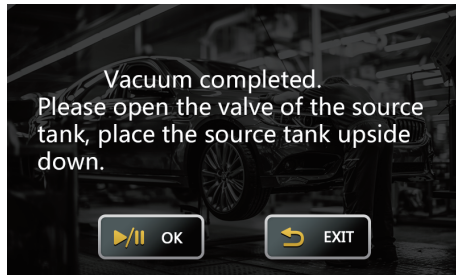
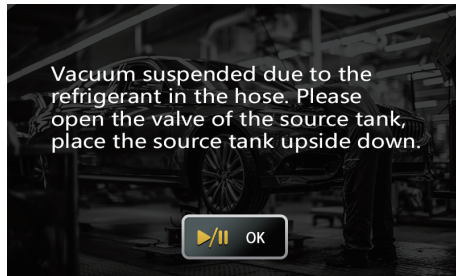

Confirm or exit based on the content.

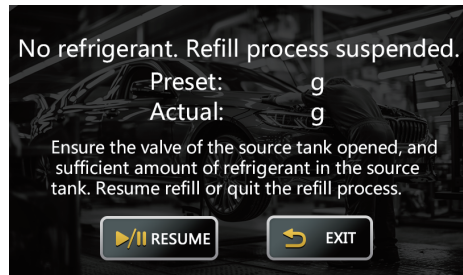
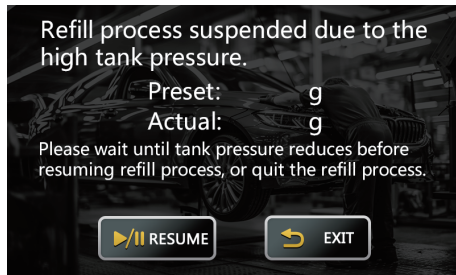
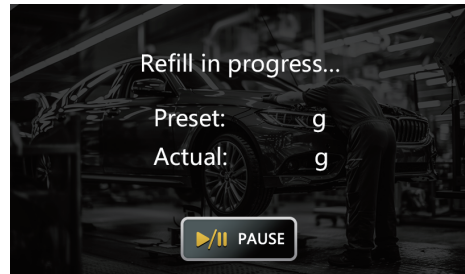

If the internal tank pressure is too high, the system will stop recharging and display the above interface. Follow the instructions to complete the operation, then choose to continue or exit.

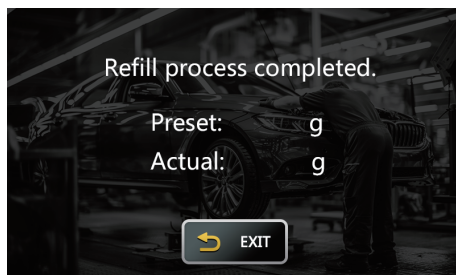

Recovery

Operation Flowchart



Select the "RECOVERY" function to enter the menu.

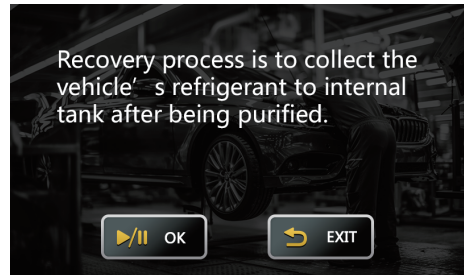

Confirm or exit based on the content.

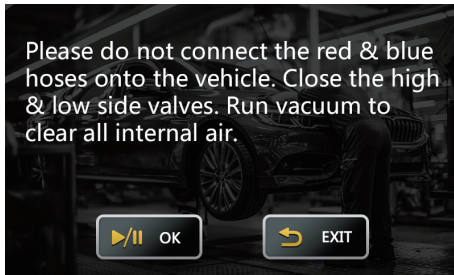

Confirm or exit based on the content.

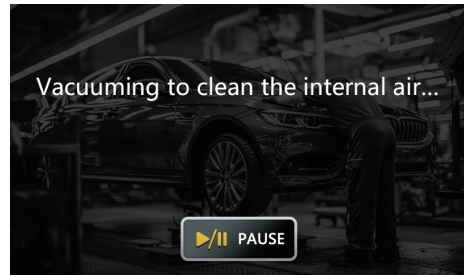

Vacuuming is operating normally; this interface appears.

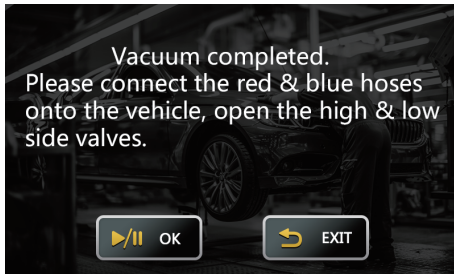

Vacuuming is completed. Follow the instructions provided in the content, then confirm or exit based on the instructions.

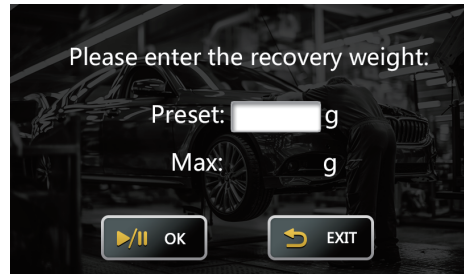

This interface appears. Follow the instructions provided in the content to complete the operation, then choose to confirm or exit.

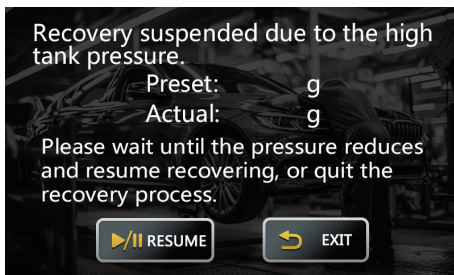

If the internal tank pressure is too high, this interface appears. Follow the instructions provided in the content to complete the operation. After completing the operation, choose to continue or exit.

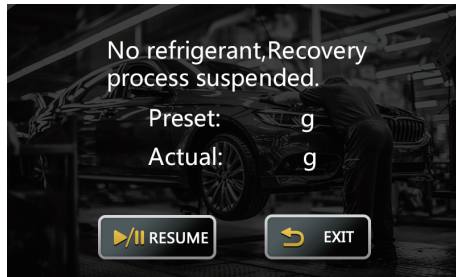

This interface appears. Open the valve and attempt to continue the recovery process or exit.

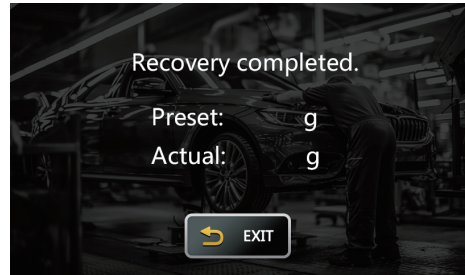
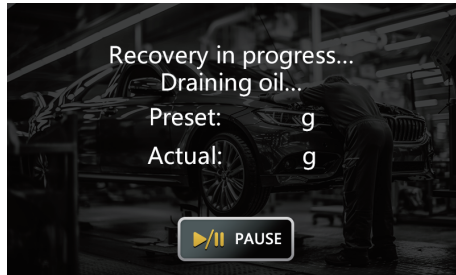

Vacuum

Operation Flowchart



Select the "VACUUM" function to enter the menu.

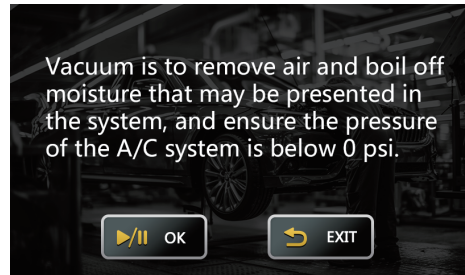

Confirm or exit based on the content.

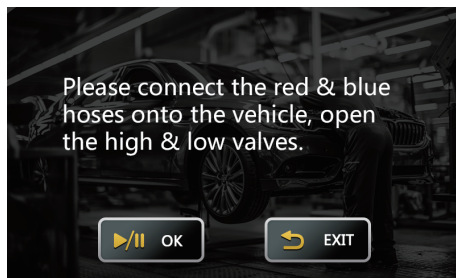

Confirm or exit based on the content.

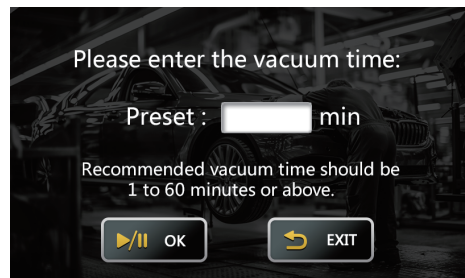

Set the vacuuming time according to the content and choose to confirm or exit.



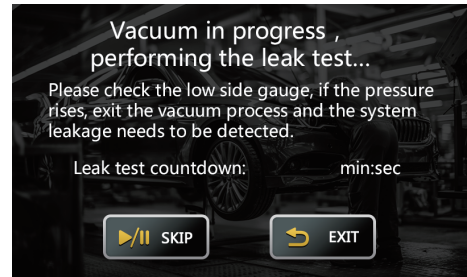

When the actual vacuuming time reaches the set time, the system displays this interface. The program enters the leak detection stage. If the user confirms that the rubber hose's tightness is good, they can choose to skip or exit.

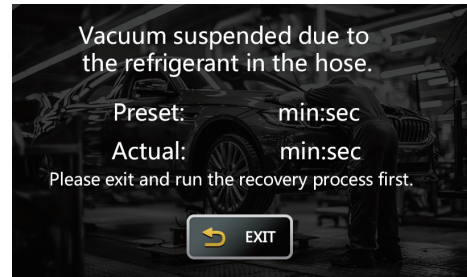
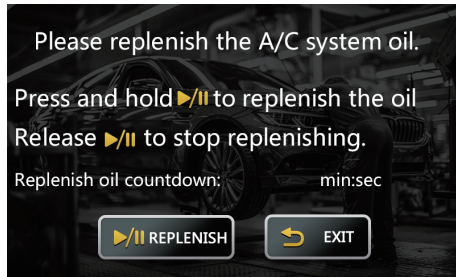

If the vacuuming fails, this interface appears. Follow the instructions to retry the vacuuming procedure or exit.

After the pressure leak test, the system will prompt to add refrigerant oil. Press and hold the add button to add oil. Note that the amount of refrigerant oil recharged depends on the amount discharged (refer to the "Internal Structure" chapter of this manual for the location of the oil discharge bottle). The increase in the liquid level is the amount of oil recharged for this operation. If there is a change in the low-pressure gauge during the pressure leak test, it indicates a leak in the air conditioning system. At this time, you should exit and check for leaks.

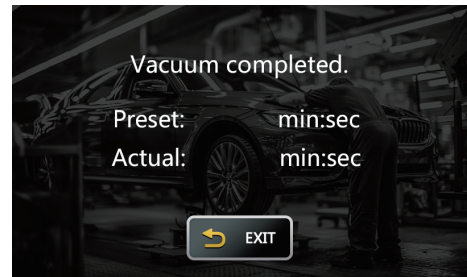

Charge

Operation Flowchart



Select the "CHARGE" function to enter the menu.

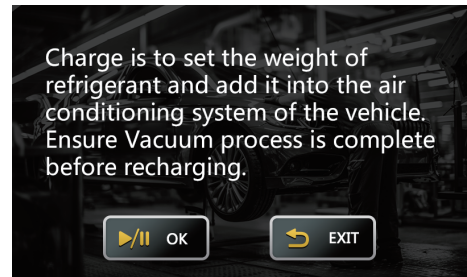

Confirm or exit based on the content.

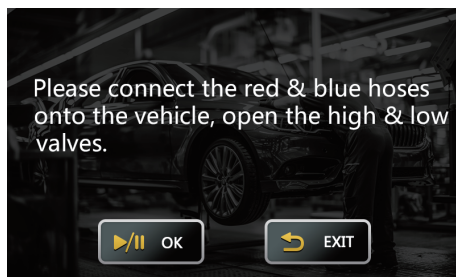

Confirm or exit based on the content.

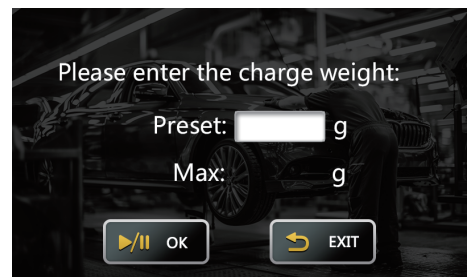

Set the amount of refrigerant to be recharged and choose to confirm or exit.

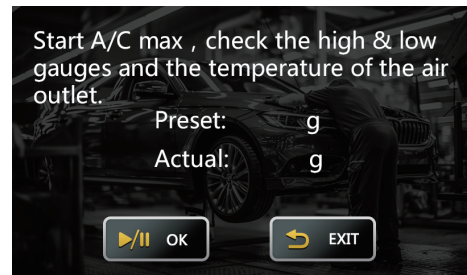
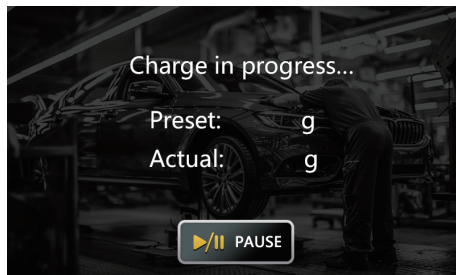

This interface appears to indicate that the recharge is completed. Follow the prompts to complete the operation, then choose to confirm or exit.

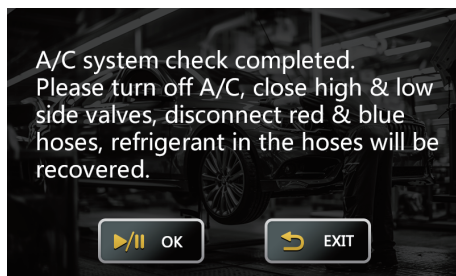

Confirm or exit based on the content.

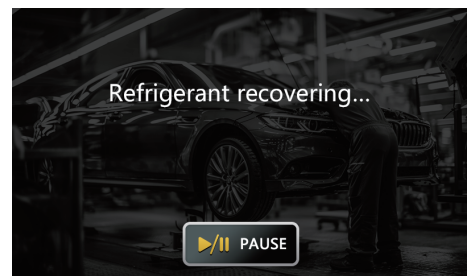

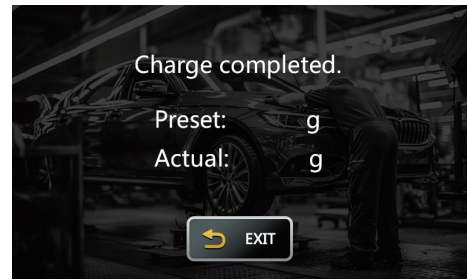
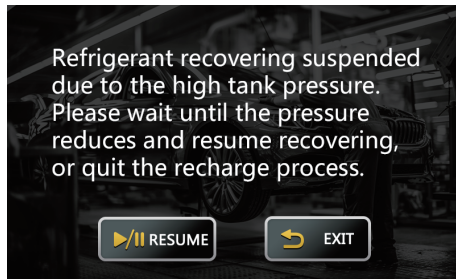

This interface appears to indicate a failure in refrigerant recovery pipeline cooling. Follow the instructions provided.

Auto. mode

Recovery+Vacuum+Recharge (Operation Flowchart)

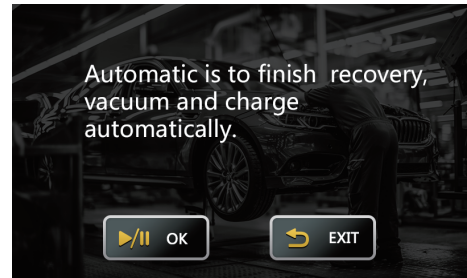

Select the "AUTO. MODE" function to enter the menu.

Confirm or exit based on the content.

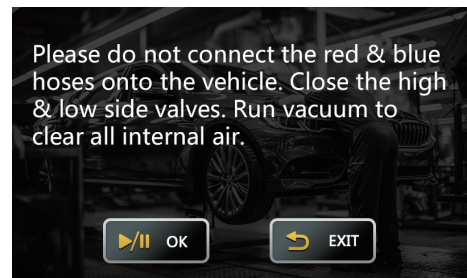
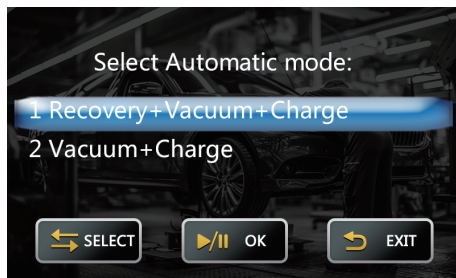

Select the first item and confirm or exit.

Confirm or exit based on the content.

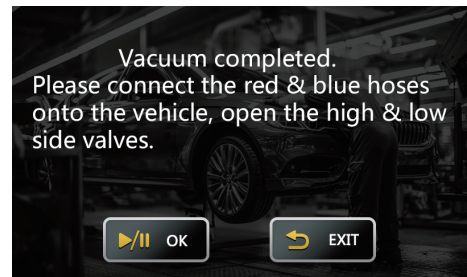
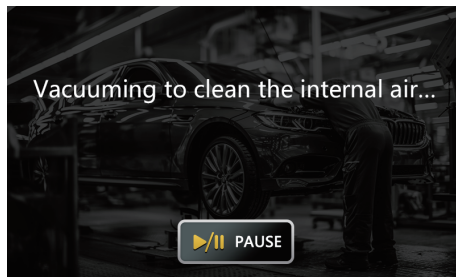

Confirm or exit based on the content.

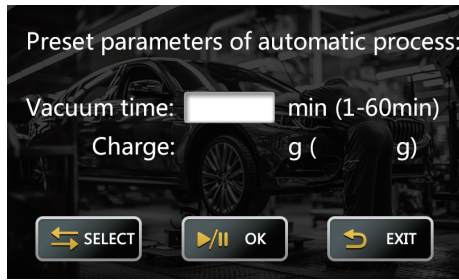

When this interface appears, the user should set the preset vacuuming time. The selection key can be used to switch to the next parameter setting. After setting is complete, choose to confirm or exit.

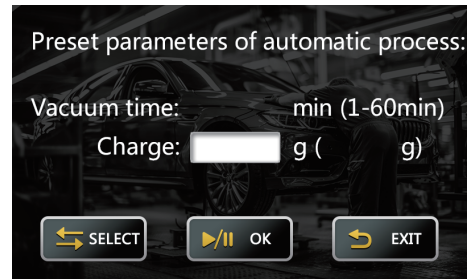

When this interface appears, the user should set the preset recharging amount. After setting is complete, choose to confirm or exit.

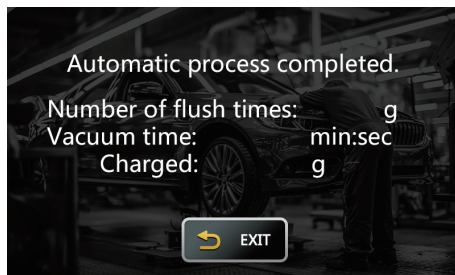
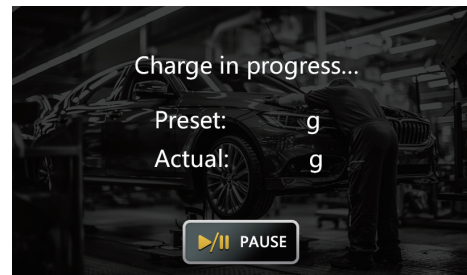
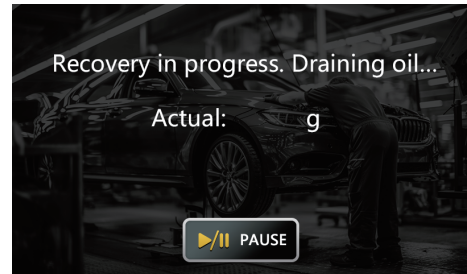
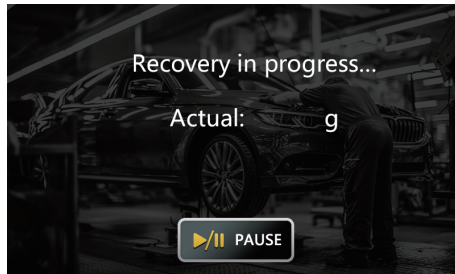

Equipment maintenance

1) Cleaning of Internal Tank

- When the internal tank is overfilled, users can run the "Internal Tank Cleaning" program under the "Equipment Maintenance" function to discharge a certain amount of refrigerant from the internal tank.

Operation Flowchart

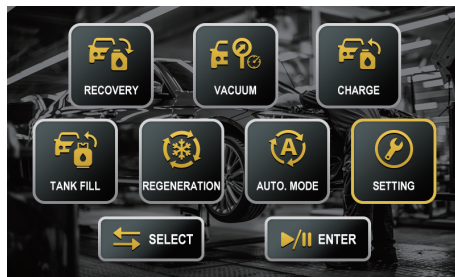

Select the "SETTING" function to enter the menu.

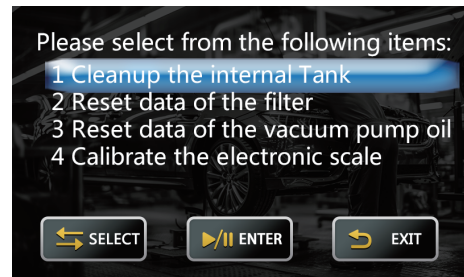

The system defaults to selecting the first item, which can be directly confirmed or exited.

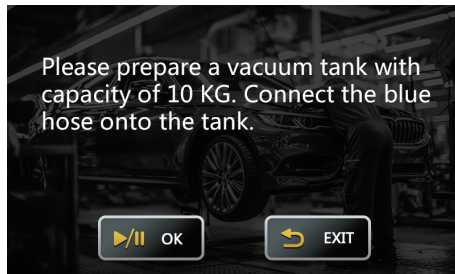

When this interface appears, set the preset discharge amount. After setting is complete, choose to confirm or exit.

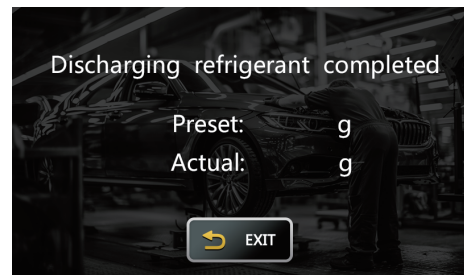
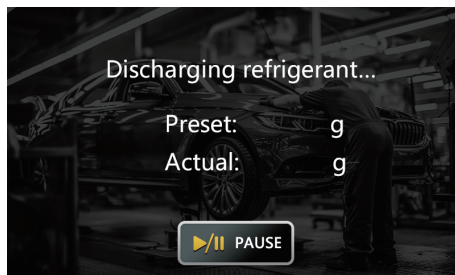
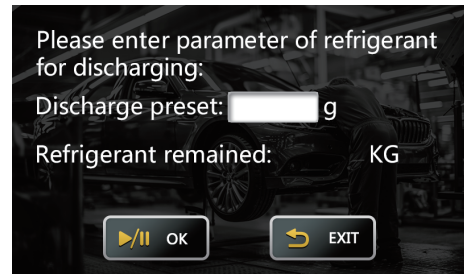

2) When this interface appears, set the preset discharge amount. After setting is complete, choose to confirm or exit.

- Each time the recovery program is executed, the system will automatically accumulate the weight of the recovered refrigerant. When the accumulation reaches 100kg, the system will prompt for a dry filter replacement, and a text prompt message will be displayed when the equipment is turned on. When the recovered refrigerant accumulates to 100kg, the system will treat it as a fault and refuse to perform any operations related to the compressor. The system will display a prompt interface as shown in the diagram.

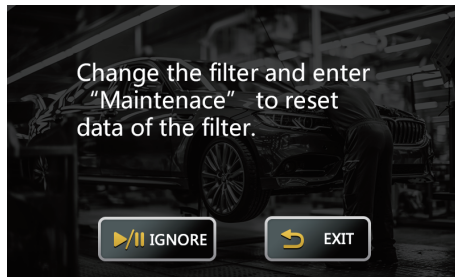

Filter Replacement Procedure

- Check the pressure on the high-pressure gauge and low-pressure gauge of the equipment. If it exceeds 150Kpa, please recover the refrigerant from the hoses.
- Open the right-side door of the equipment, where you can see the dry filter as shown below. The specific location can be found in the "Internal Structure" chapter of this manual. Remove the old dry filter and replace it with a new one. When replacing, pay attention to the installation direction of the dry filter.
- Place the new dry filter from top to bottom on the filter bracket, ensuring that the direction arrow on the filter is facing downwards.
- After replacing the dry filter, restart the equipment and run the "Reset Filter Data" program under the "Equipment Maintenance" function.



Run the Reset Dry Filter Program



Select the "SETTING" function to enter the menu.

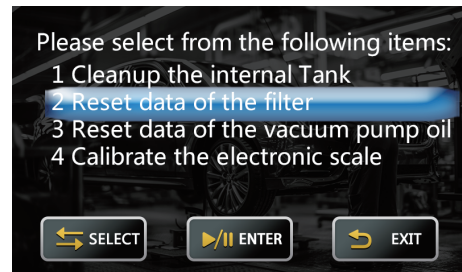

On this interface, choose the second option and confirm or exit.

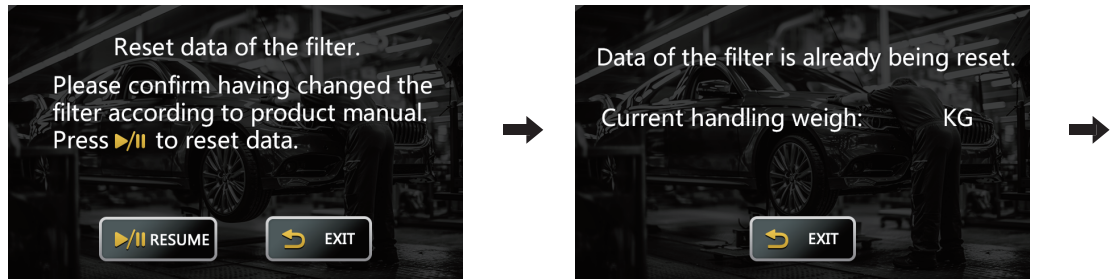

When this interface appears, follow the instructions to complete the operation. Choose to reset or exit.

3) Resetting Vacuum Pump Oil Data

The vacuum pump oil needs to be replaced under one of the following circumstances:

- When the oil level is found to be below the minimum oil level line, vacuum pump oil must be added. If the oil level is found to be too high, the drain screw at the bottom of the vacuum pump should be opened, and the oil should be drained until it is between the minimum and maximum oil level lines.
- Each time the vacuuming program is executed, the system will automatically accumulate vacuuming time. When it accumulates to 600 minutes, the system will prompt for vacuum pump oil replacement, and a text message will be displayed when the equipment is turned on. This will be treated as a fault, and the system will refuse to execute the vacuuming program and display the following prompt interface.

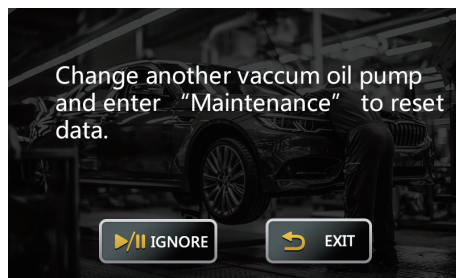

- Vacuum pump oil must also be replaced if any abnormalities are found in its quality (such as turning milky white).

⚠ NOTE

- ▶ Only use vacuum pump oil provided with the equipment or recommended by the manufacturer!

Vacuum Pump Oil Replacement Procedure

- To ensure that the vacuum pump is in a heated state, run the vacuuming program for 1 minute before changing the oil.
- Locate the vacuum pump inside the enclosure, as shown below. The specific location can be found in the "Internal Structure" chapter of this manual.
- Unscrew the nut above the vacuum pump.



- Prepare a suitable container to collect the waste oil from the vacuum pump. Use an M10 wrench to loosen the drain screw below the vacuum pump, and drain the waste oil into the container.



- After draining the oil, tighten the drain screw of the vacuum pump with the M10 wrench.
- Pour the new vacuum pump oil into the vacuum pump from above (to avoid overflow, it is recommended to use a funnel).
- When adding oil, ensure that the oil reaches the middle line position of the vacuum pump's transparent window



- After recharging, tighten the nut above the vacuum pump.
- After replacing the vacuum pump oil, restart the equipment and run the "Reset Vacuum Pump Oil Data" program under the "Equipment Maintenance" function.

Run the Reset Vacuum Pump Oil Data Program



Select the "SETTING" function to enter the menu.

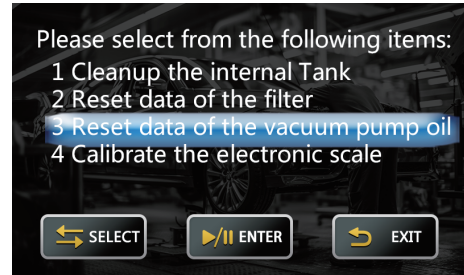

On this interface, choose the third option and confirm or exit.

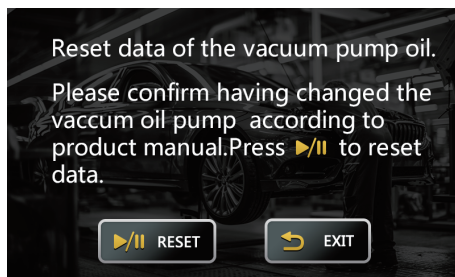

When this interface appears, follow the system prompts to complete the operation. Choose to reset or exit.

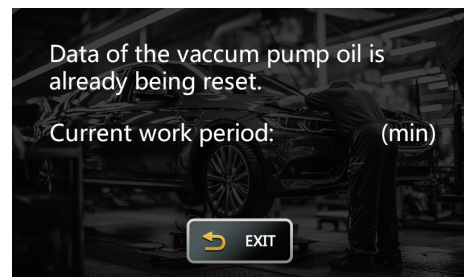

Electronic scale calibration

When the internal tank inside the equipment is replaced, or if there is a discrepancy between the displayed weight value on the electronic scale and the actual value after extended use, the "Electronic Scale Calibration" function can be used to recalibrate the scale's accuracy.

Instructions for Removing the Working Internal Tank

- Remove the back cover of the equipment to locate the internal tank, as shown in the diagram.



- Close the high and low-pressure valves of the working internal tank. The valve positions are shown in the diagram below.
- Locate the exhaust solenoid valve above the internal tank, open the yellow valve cap, and remove the black valve body.

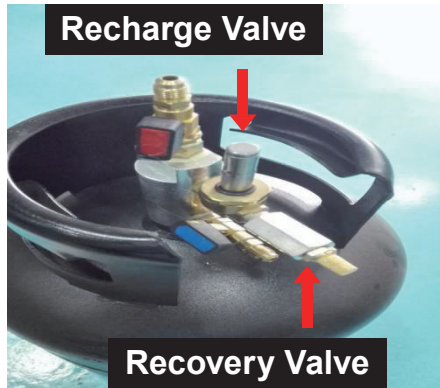

- Unscrew the fixing screws of the internal tank and remove it.



Select the "SETTING" function to enter the menu.

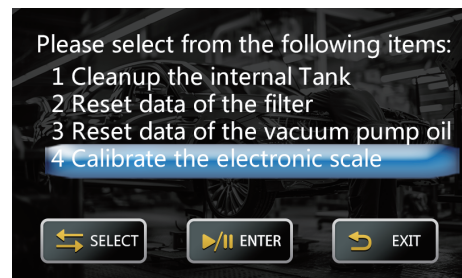

On this interface, choose the fourth option and confirm or exit.

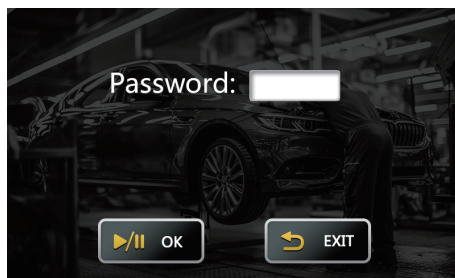

This interface is for electronic scale calibration. Please contact the manufacturer or dealer for the password.

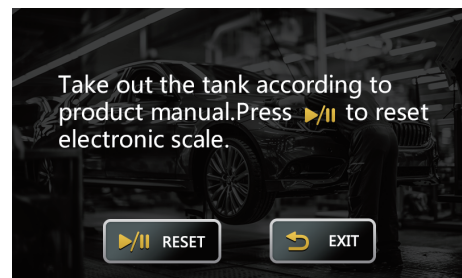

Follow the prompts to complete the operation, then choose to zero or exit.

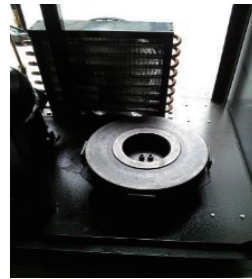
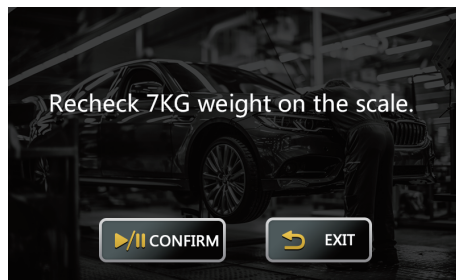

Follow the prompts to complete the operation, then choose to calibrate or exit.

- After calibration is complete, press the exit button, then reinstall the internal tank.

MAINTENANCE SERVICE

Our products are made of long-lasting and durable materials, and we insist on perfect production process. Each product leaves the factory after 35 procedures and 12 times of testing and inspection work, which ensures that each product has excellent quality and performance.

Maintenance

To maintain the performance and appearance of the product, it is recommended that the following product care guidelines be read carefully:

- Be careful not to rub the product against rough surfaces or wear the product, especially the sheet metal housing.
- Please regularly check the product parts that need to be tightened and connected. If found loose, please tighten it in time to ensure the safe operation of the equipment. The external and internal parts of the equipment in contact with various chemical media should be frequently treated with anti-corrosion treatment such as rust removal and painting to improve the corrosion resistance of the equipment and extend its service life.
- Comply with the safe operating procedures and do not overload the equipment. The safety guards of the products are complete and reliable. Unsafe factors are to be eliminated in time. The circuit part should be checked thoroughly and the aging wires should be replaced in time.
- Adjust the clearance of various parts and replace worn (broken) parts. Avoid contact with corrosive liquids.
- When not in use, please store the product in a dry place. Do not store the product in hot, humid, or non-ventilated places.

WARRANTY

From the date of receipt, we provide a three-year warranty for the main unit and all the accessories included are covered by a one-year warranty.

Warranty access

- The repair or replacement of products is determined by the actual breakdown situation of product.
- It is guaranteed that AUTOOL will use brand new component, accessory or device in terms of repair or replacement.
- If the product fails within 90 days after the customer receives it, the buyer should provide both video and picture, and we will bear the shipping cost and provide the accessories for the customer to replace it free of charge. While the product is received for more than 90 days, the customer will bear the appropriate cost and we will provide the parts to the customer for replacement free of charge.

These conditions below shall not be in warranty range

- The product is not purchased through official or authorized channels.
- The product breakdown because the user does not follow product instructions to use or maintain the product.

We AUTOOL pride ourselves on superb design and excellent service. It would be our pleasure to provide you with any further support or services.

Disclaimer

- All information, illustrations, and specifications contained in this manual, AUTOOL reserves the right of modify this manual and the machine itself with no prior notice. The physical appearance and color may differ from what is shown in the manual, please refer to the actual product. Every effort has been made to make all descriptions in the book accurate, but inevitably there are still inaccuracies, if in doubt, please contact your dealer or AUTOOL after-service centre, we are not responsible for any consequences arising from misunderstandings.

RETURN & EXCHANGE SERVICE

Return & Exchange

- If you are an AUTOOL user and are not satisfied with the AUTOOL products purchased from the online authorized shopping platform and offline authorized dealers, you can return the products within seven days from the date of receipt; or you may exchange it for another product of the same value within 30 days from the date of delivery.
- Returned and exchanged products must be in fully saleable condition with documentation of the relevant bill of sale, all relevant accessories and original packaging.
- AUTOOL will inspect the returned items to ensure that they are in good condition and eligible. Any item that does not pass inspection will be returned to you and you will not receive a refund for the item.
- You can exchange the product through the customer service center or AUTOOL authorized distributors; the policy of return and exchange is to return the product from where it was purchased. If there are difficulties or problems with your return or exchange, please contact AUTOOL Customer Service.

| | |
|---------------------|---|
| China | 400-032-0988 |
| Oversea Zone | +86 0755 23304822 |
| E-mail | aftersale@autooltech.com |
| Facebook | https://www.facebook.com/autool.vip |
| YouTube | https://www.youtube.com/c/autooltech |

目 录

| | |
|-----------------|----|
| 版权信息 | 26 |
| 版权 | 26 |
| 注册商标 | 26 |
| 注意事项 | 27 |
| 安全规程 | 27 |
| 产品简介 | 28 |
| 概述 | 28 |
| 设备功能 | 28 |
| 技术参数 | 28 |
| 产品结构 | 29 |
| 结构图 | 29 |
| 控制面板说明 | 30 |
| 内部结构 | 30 |
| 操作说明 | 31 |
| 设备与汽车连接 | 31 |
| 高低压阀门操作指引 | 31 |
| 冷媒补充 | 32 |
| 回收 | 34 |
| 抽真空 | 35 |
| 冷媒加注 | 36 |
| 自动模式 | 37 |
| 设备维护 | 39 |
| 电子称标定 | 43 |
| 维修保养服务 | 45 |
| 维修保养 | 45 |
| 保修服务 | 46 |
| 保修方式 | 46 |
| 声明 | 46 |
| 退换货服务 | 47 |
| 退换货 | 47 |

版权信息

版权

- 版权所有! 未征得深圳市偶然科技有限公司的书面同意, 任何公司或个人不得以任何形式 (电子、机械、影印、录制或其他形式) 对本说明书进行复制和备份。本手册专为偶然公司产品的使用而计, 对于将之用于指导其他设备操作而导致的各种后果, 本公司不承担任何责任。
 - 因使用者个人或第三方的意外事故, 滥用、误用该设备, 擅自更改, 或修理该设备, 或未按偶然公司的操作与保养要求而导致设备损坏、遗失所产生的费用及开支等, 偶然公司及其分支机构不承担任何责任。
 - **正式声明:**
本说明书所提及之其他产品名称, 目的在于说明该设备如何使用, 其注册商标所有权仍属原公司。
 - 本设备供专业技术人员或维修人员使用。
-

注册商标

偶然公司已在中国及海外若干国家进行了商标注册, 其标志为 **AUTOTOOL®**。本手册所提及之偶然公司其它商标、服务标志、域名、图标、公司名称均属偶然及其下属公司之产权。在偶然公司之商标、服务标志、域名、图标、公司名称还未注册之国家, 偶然公司声明其对未注册商标、服务标志、域名、图标、公司名称之所有权。本手册所提及之其它产品及公司名称的商标仍属于原注册公司所有。在未得到拥有人的书面同意之前, 任何人不得使用偶然公司或所提及的其它公司之商标、服务标志、域名、图标、公司名称。

您可以访问偶然网址: www.autooltech.com, 或发送邮件至: aftersale@autooltech.com, 与偶然公司进行联系, 征得其手册使用权之书面同意。

注意事项

安全规程



在使用本仪器之前，请仔细阅读本说明书，以便正确操作，避免造成人身伤害和仪器产品损坏事故。

- ▶ 设备的使用者须对汽车空调的维修、保养熟悉，以免损坏设备及汽车空调系统。
- ▶ 在操作过程中需穿戴保护手套和护目镜，防止制冷剂气体或液体接触到皮肤和眼睛。
- ▶ 禁止在明火和高温物体附近使用该设备。
- ▶ 请勿将设备暴露在阳光下或淋雨。
- ▶ 避免设备接触到腐蚀性液体和气体。
- ▶ 本设备只用于R134a空调系统，严禁混入其他种类制冷剂。
- ▶ 在进行操作之前，检查汽车空调所用制冷剂的类型，并关闭汽车引擎。
- ▶ 储液罐实际使用容量应为其最大存储量的80%（储液罐的容量为12kg），以避免由于外界因素产生额外压力而导致严重事故。
- ▶ 设备为了确保更好的加注功能，储液罐内不能低于3Kg制冷剂，否则可能导致无法加注。
- ▶ 排出汽车压缩机的冷冻油，通常会有气泡产生，观察排油量需等泡沫消失后，注油量由排油量决定，切勿多加。
- ▶ 定期检查真空泵油位和油质，真空泵严禁无油运行。
- ▶ 回收程序每小时最多起动次数应小于10次，否则可能会损坏压缩机。
- ▶ 日常保养时，应注意添加设备内真空泵油至正常液位（打开主机前门可观察到）。
- ▶ 设备内含精密控制元器件，请勿擅自拆卸维修。如有需要，请在专业人员的指导下进行维修。

产品简介

概述

- 本设备为冷媒回收加注机，实现对故障车辆空调系统的R134a制冷剂回收、电子称加注、抽真空、冷冻油加注等操作，各项功能均可全自动完成。

设备功能

- **源罐加注功能**
向设备内的储液罐补充制冷剂。
- **回收功能**
将R134a空调系统中的制冷剂，回收储存到设备的储存罐中，回收的过程中对制冷剂进行净化再生。
- **抽真空功能**
对制冷系统抽真空。
- **加注功能**
将储存在设备储存罐中的制冷剂精确地加注到制冷系统中。
- **自动操作功能**
自动操作是设备自动完成回收、抽真空、加注。
- **设备维护功能**
维护设备部件，包括“储液罐清理”、“重置过滤器数据”、“重置真空泵油数据”、“电子称标定”。
- 本设备为了确保充分回收和精确加注，配置了管路补偿功能，同时在每次倒罐和回收操作前，都将自动对管路抽真空；在每次加注完成后，会自动把管路内的制冷剂回收到设备的储液罐内。

技术参数

| | |
|--------|--------------|
| 电源 | AC 220V/50HZ |
| 电功率 | 800W |
| 工作环境温度 | 10°C-50°C |
| 电子称精度 | ±10g |
| 回收能力 | 400g/min |
| 真空泵能力 | 5Pa |
| 储存罐容量 | 12Kg |
| 充注速率 | 800g/min |

产品结构



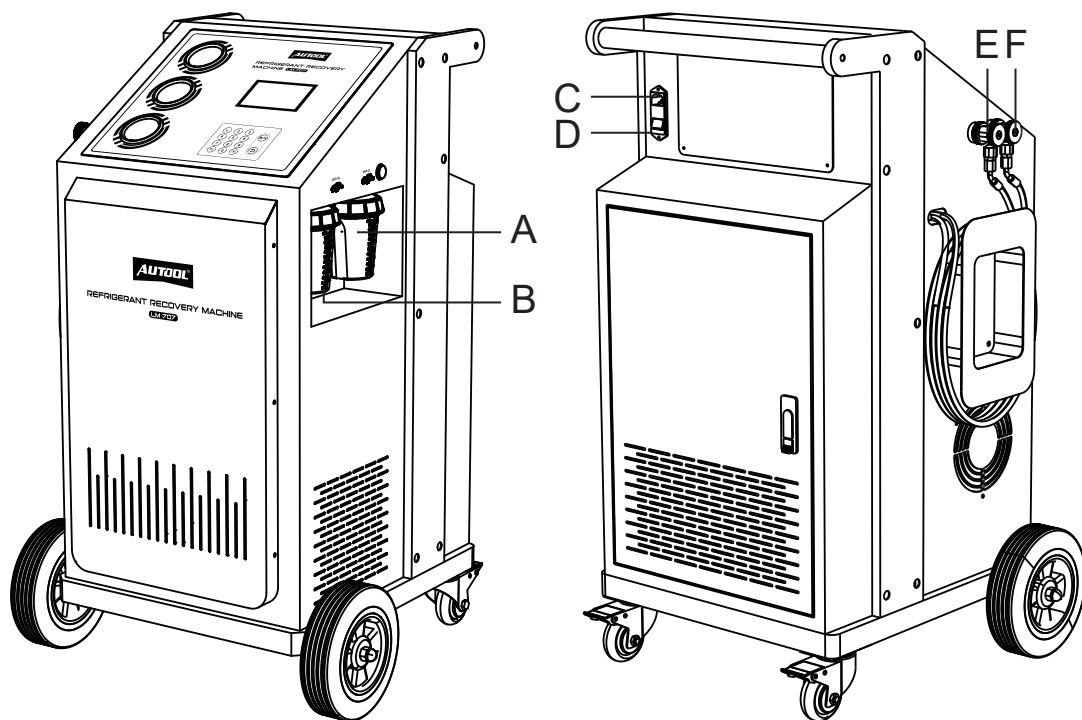

结构图

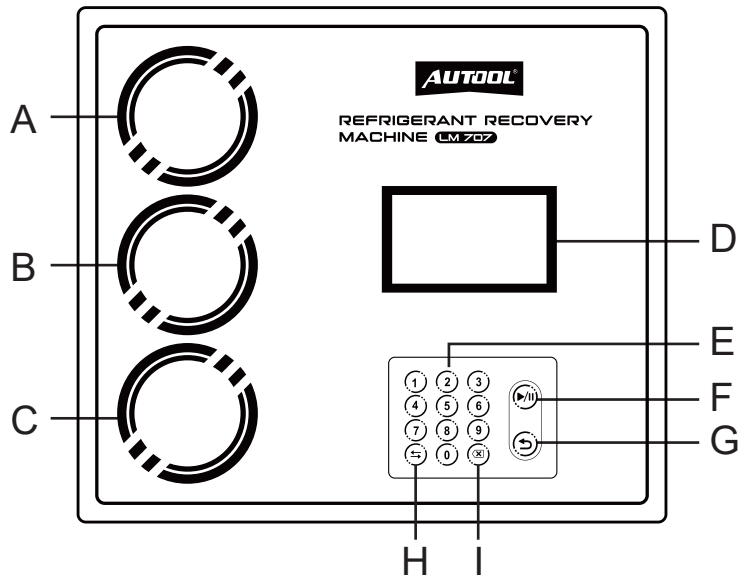

| | | | |
|----------|------|----------|------|
| A | 新油瓶 | B | 旧油瓶 |
| C | 电源插座 | D | 电源开关 |
| E | 低压接头 | F | 高压接头 |

控制面板说明



| | | | |
|----------|---|----------|--|
| A | 高压表 | B | 低压表 |
| C | 储罐压力表 | D | 显示屏 |
| E |  数值按钮 (0~9) | F |  开始/暂停按钮 |
| G |  退出按钮 | H |  功能选择按钮 |
| I |  撤销按钮 | | |

内部结构

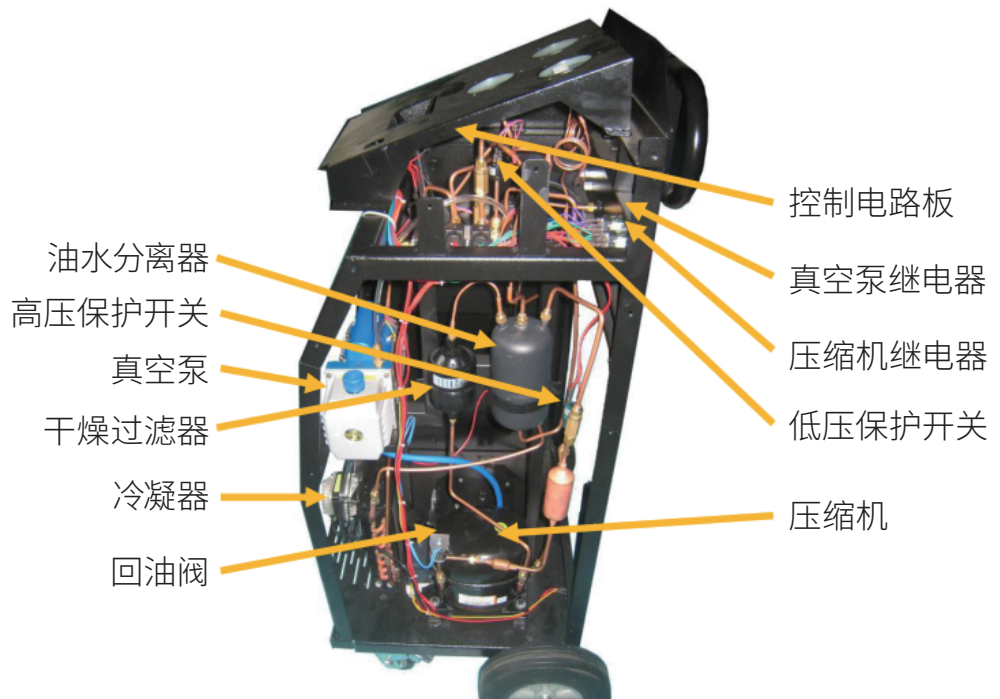

操作说明

设备与汽车连接

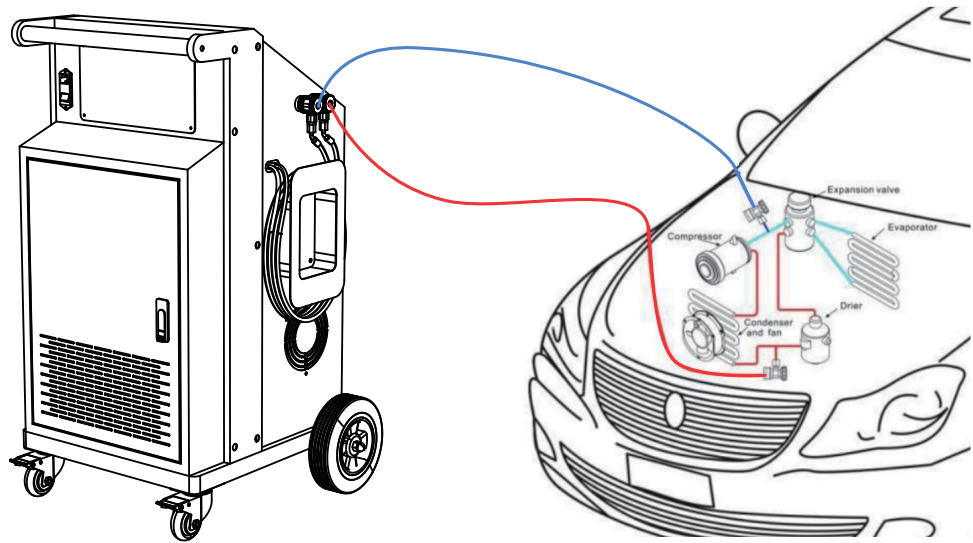

高低压阀门操作指引

设备在操作过程中，系统会多次提示“关闭高低压阀门”“打开高低压阀门”，其操作定义以下：

关闭高低压阀门

- 以下图所示，关闭高低压阀门是指按高低压阀门上箭头的反方向（高低压阀门上有标注“open”的箭头），逆时针拧紧高低压阀门的操作。

关闭空调快接示意图

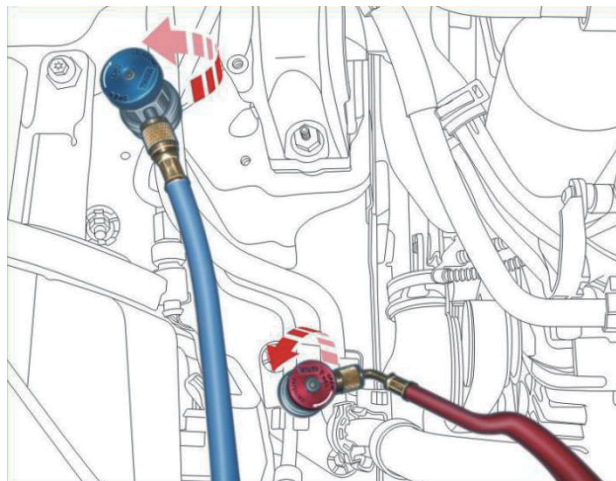

逆时针拧紧空调快接

打开高低压阀门

- 以下图所示，打开高低压阀门是指按高低压阀门上箭头方向（高低压阀门上有标注“open”的箭头），顺时针拧紧高低压阀门的操作。

打开空调快接示意图

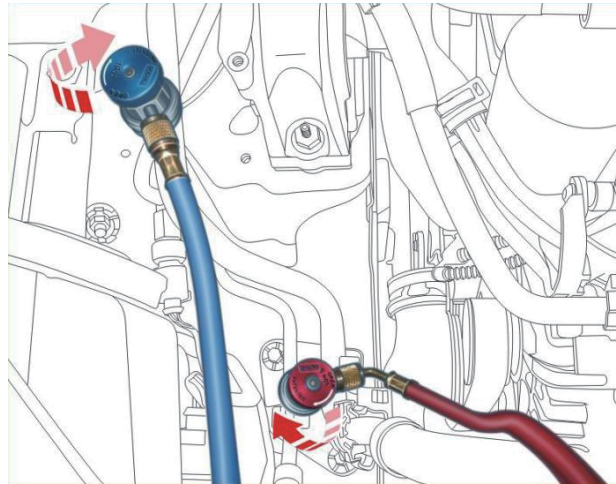

顺时针拧紧空调快接

冷媒补充

设备在出厂时，储液罐是没有制冷剂的，必须在使用前向设备内储液罐充注制冷剂。建议的充注重量3-6kg之间，操作如下：

- 把蓝色软管安装到主机的低压接头上。
- 把蓝色软管的快速接头连接到源罐的接头上。
- 关闭红色软管的快速接头。

操作流程图

- 在主菜单界面，按选择键选择所需功能，按进入菜单键进入所需功能。



选择源罐加注功能进入菜单。



根据内容选择确认或退出。



根据内容选择确认或退出。



抽真空正常运行，出现此界面。



根据内容选择确认或退出。

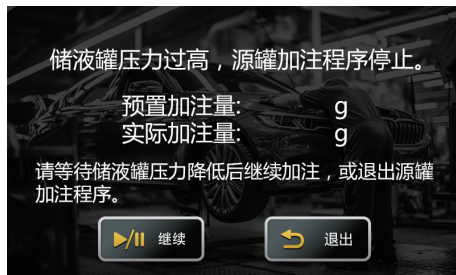

若出现储液罐压力过高，系统停止加注并出现以上界面，用户应按指引完成操作，选择继续或退出。



回收

操作流程图



选择回收功能进入菜单。

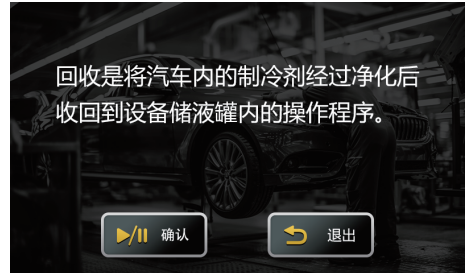

根据内容选择确认或退出。



根据内容选择确认或退出。



抽真空正常运行，出现此界面。



抽真空完成，根据内容指示完成操作并选择确认或退出。



出现此界面，用户应按照指引完成操作，选择确认或退出。

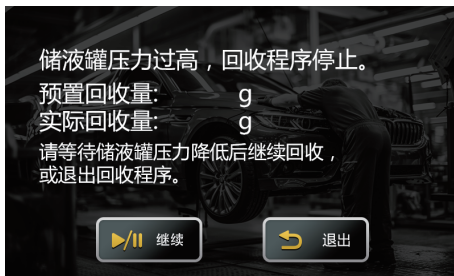

若出现储罐压力过高，出现此界面，用户应按内容指引操作，操作完成选择继续或退出。



出现此界面，应打开阀门后尝试继续回收程序或退出。



抽真空

操作流程



选择抽真空功能进入菜单。

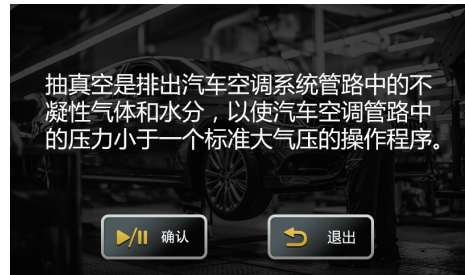

根据内容选择确认或退出。



根据内容选择确认或退出。

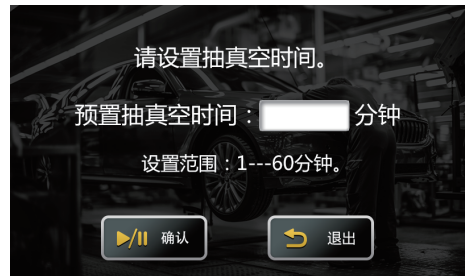

根据内容设置抽真空时间并选择确认或退出。

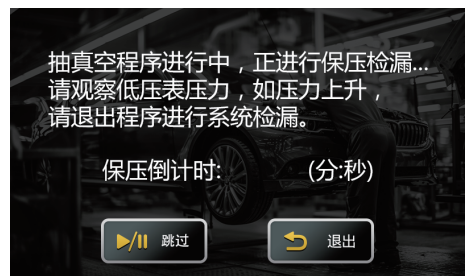

当实际抽空时间达到设定时间时系统显示此界面, 程序进入保压检漏阶段, 如果用户确定系统回路密封性良好可选择跳过或退出。



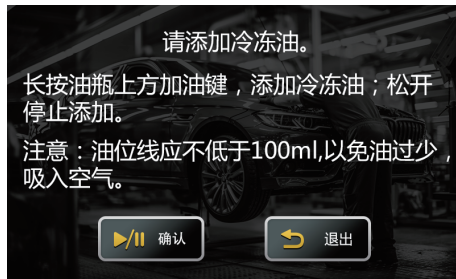

保压完成后，系统将提示加入冷冻油，长按加键进行加油。请注意冷冻油的加注量由排油量决定(排油瓶位置见本手册“产品结构”一章“内部结构”。液位的增加量即是本次操作的加注量)，如果在保压过程中，低压压力表有变化，说明空调系统内有漏点，此时应按退出并检漏。

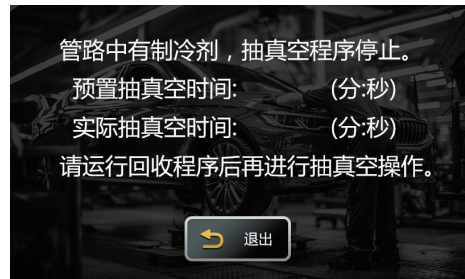

若抽真空失败出现此界面，用户应按指引操作后重新运行抽真空程序或退出。



冷媒加注

操作流程图



选择冷媒加注功能进入菜单。

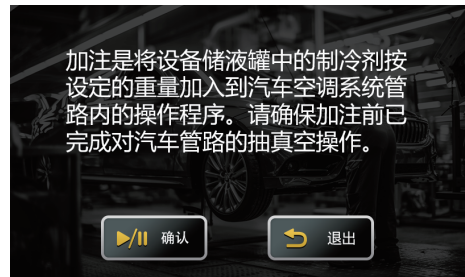

根据内容选择确认或退出。



根据内容选择确认或退出。

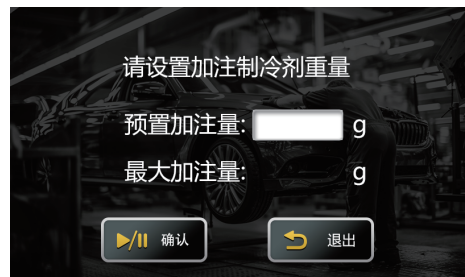

设置加注量，选择确认或退出。



出现此界面表示加注完成，应按照提示操作，完成操作选择确认或退出。

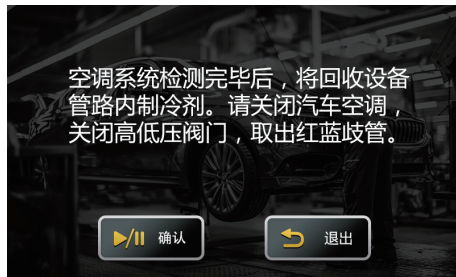

根据内容选择确认或退出。



出现此界面表示回收管路制冷失败，应按照指引操作。

自动模式

回收+抽真空+加注 (操作流程图)



选择自动模式功能进入菜单。

根据内容选择确认或退出。



选择第一项并确认或退出。



根据内容选择确认或退出。

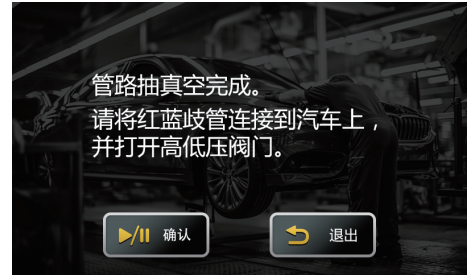

根据内容选择确认或退出。



出现此界面, 用户应设置预置抽真空时间, 选择键可切换至下一项参数设置, 设置完成选择确认或退出。



出现此界面, 用户应设置预置加注量, 设置完成选择确认或退出。



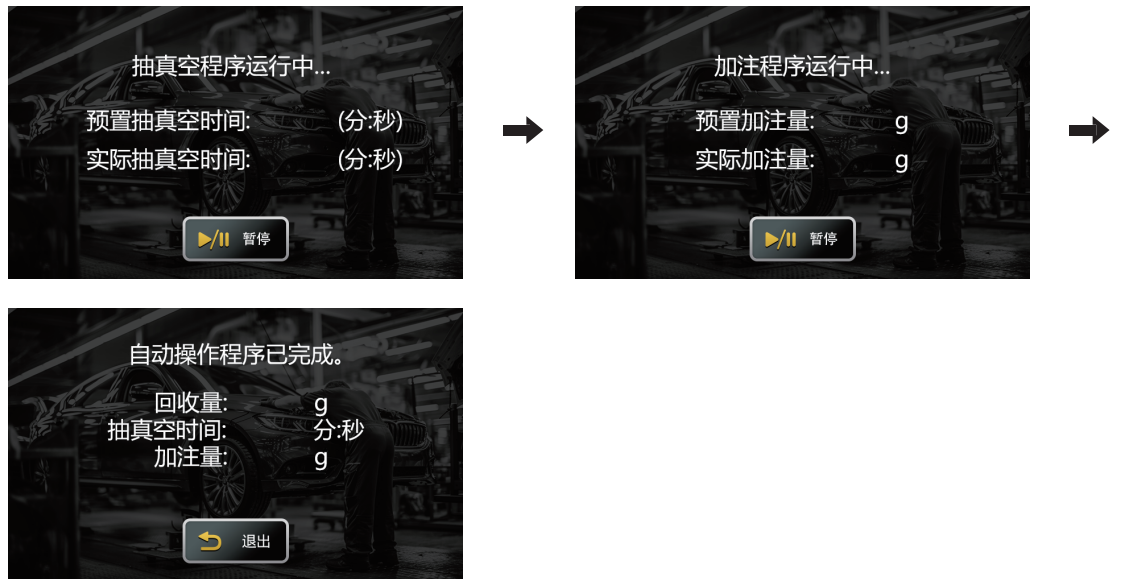

设备维护

1) 储液罐清理

- 储液罐过满时, 用户可运行“设备维护”功能的“储液罐清理”程序, 排出储液罐中一定量的制冷剂。

操作流程图



选择设备维护功能进入菜单。

系统默认选择第一项, 可直接选择确认或退出。

出现此界面, 应设置预置排除量, 设置完成选择确认或退出。

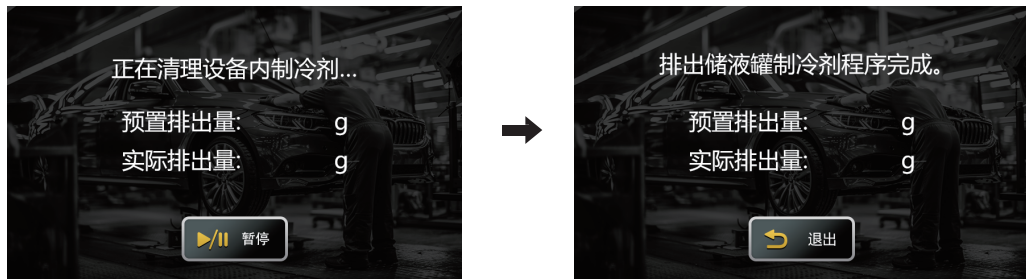

2) 重置干燥过滤器数据

- 每次执行回收程序时，系统会自动累计储存回收制冷剂重量。累计到100Kg时，系统会提示更换干燥过滤器，在开机时会显示文字提示信息。当回收制冷剂累计到100Kg时，系统将视作故障处理，并且将拒绝执行和压缩机有关的所有操作，系统会显示如图提示界面。



更换过滤器步骤

- 检查设备高压表和低压表压力。如果高于150Kpa请回收完软管内的制冷剂。
- 打开设备右侧门，即可见到如下所示的干燥过滤器，其具体位置可参考本手册“产品结构”一章“内部结构”。拆出旧的干燥过滤器，换上新的干燥过滤器即可。在更换时请注意干燥过滤器安装方向。
- 把新的干燥过滤器自上而下安放在过滤器支架上，确认过滤器上的方向箭头标贴向下。
- 更换完干燥过滤器后重新开机，运行“设备维护”功能的“重置过滤器数据”程序。



运行重置干燥过滤器程序



选择设备维护功能进入菜单。



出现此界面选择第二项并确认或退出。



出现此界面，用户应按照指引完成操作，选择重置或退出。



3) 重置真空泵油数据

以下情况之一需要更换真空泵油:

- 当检查到油面低于最低油位线时，必须添加真空泵油。当发现油位太高时，应打开真空泵底部的放油螺丝，把油放至最低和最高油位线之间。
- 每次执行抽真空程序时，系统会自动累计抽真空时间。当累计到600分钟，系统会提示更换真空泵油，在开机时会以文字信息提示。并视作故障处理，系统将拒绝执行抽真空程序，并显示以下提示界面。



- 当发现真空泵油油质异常（变为乳白色时）也必须更换。

⚠ 注意

- ▶ 必须使用设备自带的或制造厂商推荐的真空泵机油!

更换真空泵油步骤

- 为确保真空泵处在热态，换油时首先运行抽真空程序1分钟。
- 找到机箱内的真空泵，如下所示，其具体位置可参考本手册“产品结构”一章“内部结构”。
- 拧开真空泵上方的螺母。



- 准备一个合适的容器用于承接真空泵废油，用M10扳手拧开真空下的排油螺母，将真空泵废油排到容器中。



- 排油完成后，用M10扳手拧紧真空泵排油螺母。
- 把新的真空泵油从真空泵上方倒入真空泵中（为避免真空泵油外溢，建议用漏斗导入）。
- 加油时，务必使油加至真空泵透明窗的中线位置。



- 加油完毕后拧紧位于真空泵上方的螺母。
- 更换完真空泵油后重新开机，运行“设备维护”功能的“重置真空泵油数据”程序。

运行重置真空泵油数据程序



选择设备维护功能进入菜单。



出现此界面择第三项并确认或退出。



出现此界面，用户应根据系统提示完成操作，选择重置或退出。



电子称标定

设备内的储存罐更换后，或设备使用很长时间后电子称显示的重量值和实际值有偏差时可以通过“电子秤标定”重新标定电子秤的精度。

取出工作储液罐说明

- 拆开设备后盖，找到储液罐位置，如图所示。



- 闭工作储液罐罐高低压阀门，阀门位置如下图所示。
- 找到位于储液罐上方的排气电磁阀，打开黄色阀盖，将黑色阀体取出。



- 把储液罐的固定螺丝拆下，将储液罐取出。



选择设备维护功能进入菜单。



出现此界面择第四项并确认或退出。



此界面为电子秤标定，密码请联系厂家获取。



根据此指引完成操作，选择清零或退出。



据指引完成操作，选择校准或退出。

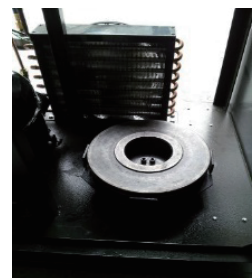

- 校准完毕后，按退出键，然后安装好储液罐。

维修保养服务

您所拥有的AUTOOL产品选用持久耐用的材料，AUTOOL坚持精益求精的生产工艺，每一件产品出厂都经过35道工序及12次质检工作，从而确保每一件产品都拥有卓越的品质及性能。所以您的AUTOOL产品值得您定期维护保养，使其产品将能够长期稳定地工作。

维修保养

维护保养是为了保持产品性能和外观，我们建议您仔细阅读以下产品保养指南：

- 注意不要将产品与粗糙表面摩擦或揉搓产品，特别是钣金外壳。
- 对产品中需要紧固和连接的部位经常进行检查，如发现松动应及时紧固，以保证产品的安全运行。对与各种化学介质接触的产品外部和内部零件要经常进行除锈、喷漆等防腐处理，以提高产品的抗腐蚀能力，延长产品的使用寿命。
- 遵守安全操作规程，不超负荷使用产品。产品的安全防护装置齐全可靠，及时消除不安全因素。电路部分彻底检查，老化电线要及时更换。
- 定期清洗和更换易耗部件；调整各部位配合间隙和更换磨损（已坏）部件清洁时，避免产品接触带腐蚀性的液态物品。
- 不使用时，请将产品存放于干燥的位置。不要将产品存放在高温、潮湿或不通风的地方。

保修服务

AUTOOL主机自客户签收日起享有3年保修期。其所含附件自客户签收日起享有1年保修期。

保修方式

- 根据具体的故障情况对产品进行免费修理或更换；
- 我方保证所有更换的部件、附件或产品都是全新；
- 在客户收到产品90天内出现故障同时提供视频和图片，我方承担运费并免费提供相应配件给客户更换。收到产品超过90天，客户承担相应的费用，我方免费提供配件给客户更换；

以下情况不在免费保修范围：

- 非正规渠道购买AUTOOL的产品；
- 未按产品说明书要求使用和维护造成的损坏；

在AUTOOL，我们为精湛的设计和卓越的服务感到自豪。我们很乐意为您提供更多的支持或服务。

声明

- 偶然公司保留更改产品设计与规格的权利，届时恕不另行通知。实物外观与颜色可能与说明书中显示的有差别，请以实物为准。我们已尽最大努力力求使书中所有描述准确，但仍难免有不妥之处。如有疑问，请联系经销商或偶然售后服务中心。本公司对产品拥有最终解释权，不承担任何因误解而产生的后果。

退换货服务

退换货

- 如果您对从线上授权购物平台和线下授权经销商所购买的AUTOOL产品不满意, 根据《AUTOOL全球销售条款》, 您可以自收到产品之日起七日内退货; 或者在产品交付之日起的30日内调换等值的其他产品。
- 退回及调换的产品必须处于完全可销售状态, 并附上相关销售单单据, 所有相关配件、纸质发票 (如有)。
- AUTOOL将会对寄回退货的商品进行检查, 以确保其处于完好无损的状态并且符合条件, 相关条件详情请参阅《AUTOOL全球销售条款》。任何未通过检查的商品将退还给您, 您将不会获得商品退款。
- 您可以通过客户服务中心或AUTOOL授权经销商调换产品; 退换货原则为从哪里购买, 就从哪里退换货。如果您退换货遇见困难或者阻碍, 请联系AUTOOL客户服务中心。通过客户服务中心退换货时, 我们建议您通过下面的方式进行:

| | |
|----------|---|
| 中国区域致电 | 400-032-0988 / 18929303778 |
| 售后微信号 | 18929303778 |
| 海外区域致电 | +86 0755 23304822 |
| E-mail | aftersale@autooltech.com |
| Facebook | https://www.facebook.com/autool.vip |
| YouTube | https://www.youtube.com/c/autooltech |

- 如您的退换货得到确认, 您将收到确认信息和邮件。